

PRODUCT CODE:-

ENP-LD5-20

CATEGORY:-

NEMA TWIST LOCK PLUG

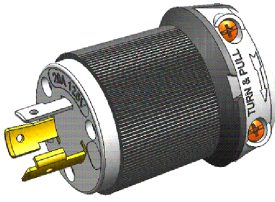

Twist Lock L5-20P
20Ampere,125volt
2 Pole,3 Wire Grounding



BASIC DIMENSIONS:-

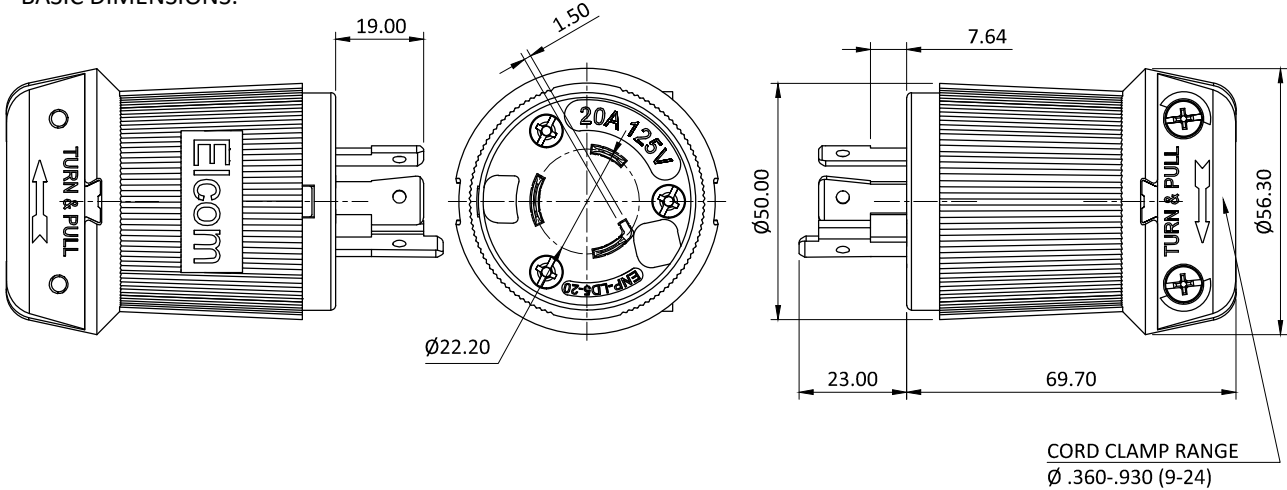

SPECIFICATION TABLE:-

SR.NO.	PARAMETER		SPECIFICATION
1	Connector Type		Twist lock L5-20P type
2	V/A Rating		125Vac, 20A
3	Insulation Resistance At 500 V DC		100 Mohms min.
4	H.V.Break Down Test (For 1-Minute)		2 KVAC
5	Terminals		Screw-type 12 AWG
6	Permissible Temp.	(a) With/Without Load	0°C TO 75°C
7	Material	(a) Body	Nylon, Black
		(b) Cord Clamp	Nylon, Natural (White) Tightening Torque : 18-21 Kg-cm.
		(c) Contact Holder	Nylon, Natural (White)
		(d) Retainer	Polycarbonate, Clear
		(e) Contact Blades	Copper Alloy Nickel Plated / Unplated
		(f) Terminal screws	Brass Tightening Torque : 12 Kg-cm min.
8	Reference Standard		UL-498, NEMA WD 6 CSA C22.2 No.42
9	Approvals		File No. E362808 (UL LISTED)
10	Flammability		UL 94, V-0

						APP	12.04.14	GJG	<p>Plot E-4, Kagal Five Star MIDC, Kagal, Kolhapur, MH - 416236, India Elcom International Pvt. Ltd. www.elcom-in.com</p>	
						CHK	12.04.14	PGP		
						DRN	12.04.14	SSP		
REV	IS	WAS	DATE	SIGN	APP.	BY	DATE	SIGN		
UNSP.TOLERANCE			DIMNS. IN	WT(Gm)	SCALE:-	PROJECTION	SHEET	DRAWING NUMBER		
OVER	-	1	10	mm	Max.	NTS.		1 OF 1	P E N P 2 5 2 0	REVISION
UP TO	1	10	-	Moulding, plating details as per Bill of Material Unspecified colour is Black, GF:Glass filled.						0
±	0.2	0.3	0.5							

F:ENG-08.00

Note: Technical specifications are subject to change without prior notice

Copyright © 2019 by Elcom International Pvt.Ltd, India. All rights reserved