

PRODUCT CODE:-

**ENP-LD6-30**

CATEGORY:-

**NEMA TWIST LOCK PLUG**

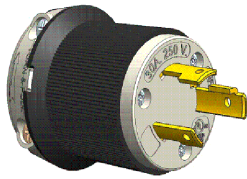

Twist Lock L6-30P Type  
30 Ampere, 250volt  
2 Pole, 3 Wire Grounding

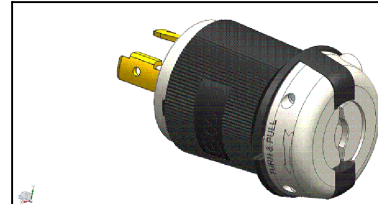

**BASIC DIMENSIONS:-**

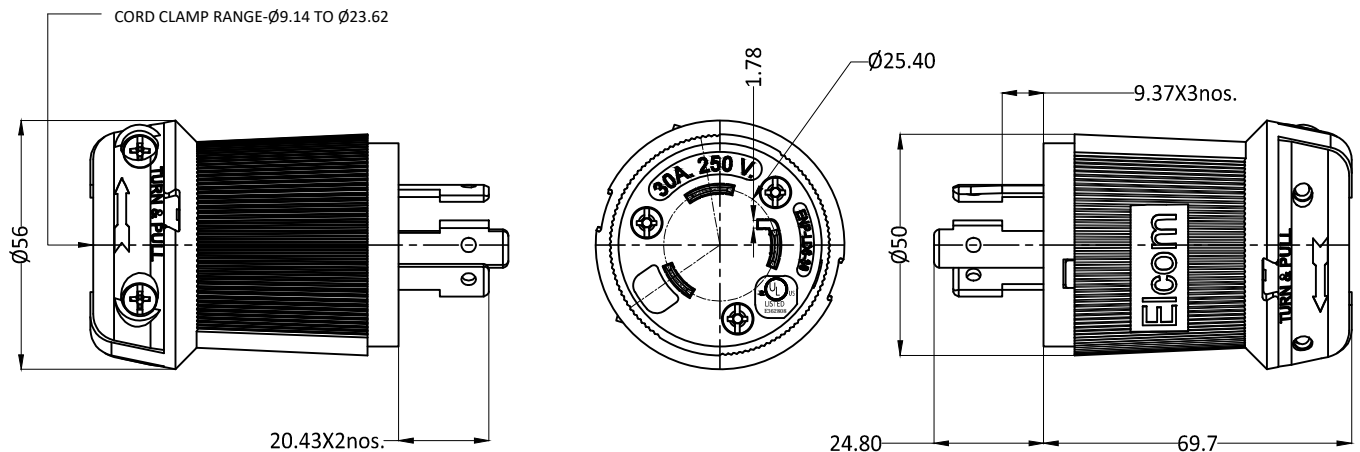

**SPECIFICATION TABLE:-**

SR.NO.	PARAMETER		SPECIFICATION
1	Connector Type		Twist lock L6-30P type
2	V/A Rating		250Vac, 30A
3	Insulation Resistance At 500 V DC		100 Mohms min.
4	H.V.Break Down Test (For 1-Minute)		2 KVAC
5	Terminals		Screw-type 10 AWG
6	Permissible Temp.	(a) With/Without Load	0°C TO 75°C
7	Material	(a) Body	Nylon, Black
		(b) Cord Clamp	Nylon, Natural (White) Tightening Torque : 18-21 Kg-cm.
		(c) Contact Holder	Nylon, Natural (White)
		(d) Retainer	PolyCarbonate, Clear
		(e) Contact Blades	Copper Alloy.
		(f) Terminal screws	Brass Tightening Torque : 12 Kg-cm min.
8	Reference Standard		UL-498, UL-486E, NEMA WD 6 CAN/CSA C22.2 No.0-M91, CSA C22.2 No.42-99
9	Approvals		File no.E362808 (UL LISTED)
10	Flammability		UL 94, V-0

						APP	12.04.14	GJG	<p>Plot E-4, Kagal Five Star MIDC, Kagal, Kolhapur, MH - 416236, India Elcom International Pvt. Ltd. www.elcom-in.com</p>	
						CHK	12.04.14	KAK		
						DRN	12.04.14	Sagar		
REV	IS	WAS	DATE	SIGN	APP.	BY	DATE	SIGN	DRAWING NUMBER	
UNSP.TOLERANCE			DIMNS. IN	WT(Gm)	SCALE:-	PROJECTION	SHEET	P E N P 2 6 3 0		
OVER	-	1	10	mm	Max.	NTS.		1 OF 1	REVISION	
UP TO	1	10	-	Moulding, plating details as per Bill of Material Unspecified colour is Black, GF:Glass filled.					0	
±	0.2	0.3	0.5							

F:ENG-08.00

Note: Technical specifications are subject to change without prior notice

Copyright © 2019 by Elcom International Pvt.Ltd, India. All rights reserved